

参考用图	√
开模用图	
生产用图	

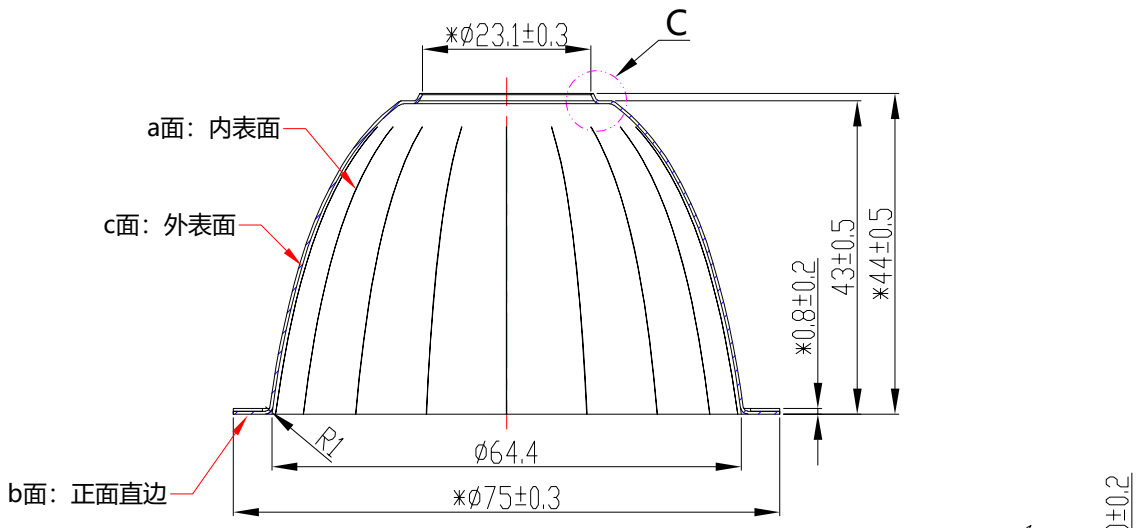

A - A

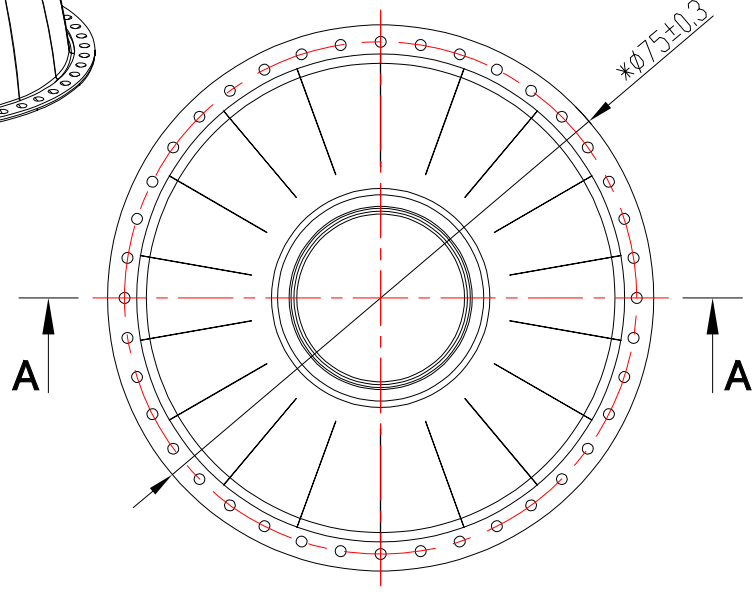
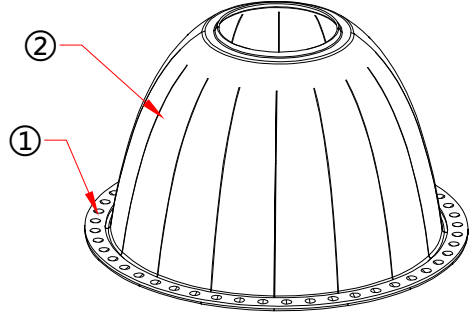
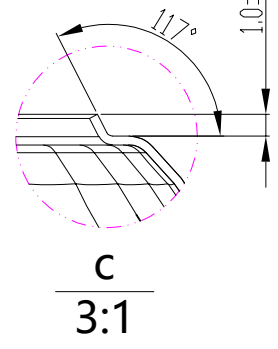

Light Source	CITIZEN CLU038
PlasticHolder	92.70.412.00
Metal Adaptor	
Design Angle	38°±3°
Measured Angle	37.8°
Efficiency	

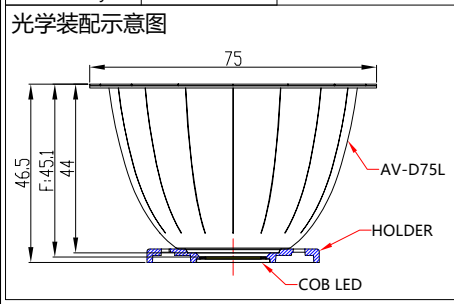

- 技术要求:
1. "\*"标记为重点控制尺寸。
  2. 未注公差按公差表。
  3. 产品未注圆角与拔模斜度按3D。
  4. 产品外观按《N-SIP-QA-04 铝反光杯检验标准》。

PRODUCT BOM				
NO.	PRODUCT NAME	PRODUCT CODE	QUANTITY	MATERIAL/FINISH
①	铝圈	97.76.692.00	1	T=0.6mm 1060AL H22
②	2-1779-A	94.02.1779.000	1	T=0.4mm High reflectivity aluminum (sanded surface)

标记	处数	更改内容	签名	更改日期
MARK	NO. OF MODIF.	MODIFICATIONS	SIGNED BY	MODIF. DATE
设计		制图	比例	1:1
DESIGNER		DRAWN BY	SCALE	
工艺		审核	视角	
TECHNICIAN		CHECKED BY	1st ANGLE PROJECTION	
批准		日期	页数	SHEET 1 OF 1
APPROVED BY		DATE (DD-MM-YYYY)	PAGE	
		29-11-2024		

DIMENSION TOLERANCE TABLE (UNLESS OTHERWISE STATED)							
> 0-5	> 5-30	> 30-90	> 90-150	> 150-250	> 250-400	> 400-700	
±0.15	±0.2	±0.4	±0.5	±0.8	±1.5	±2	

PUNCH TOLERANCE TABLE (UNLESS OTHERWISE STATED) (ANGLE)					
> 0-10	> 10-50	> 50-120	> 120-250	> 250-360	
±1°	±0.5°	±0.3°	±0.2°	±0.166°	

部件产品图  
COMPONENT PRODUCT DRAWING

**Nata**® 版本 V1.0

产品编码 PRODUCT CODE	91.02.2062.001
产品名称 PRODUCT NAME	2-2062-L2
客户代号 CUSTOMER ID	NT
客户编号 CUSTOMER CODE	AV-D75L切合反光罩-38D